

LP3971 USB Evaluation Board

National Semiconductor
Application Note 1620
Sheldon Mah
May 2007



General Description

The LP3971 Flex PMU is a complete power management IC designed for advanced applications processors. It contains 5 low noise low dropout regulators, 3 DC/DC buck converters, a backup battery charger, real time clock supply regulator [RTC], 2 GPO's and high speed I²C serial interface to program individual regulator output voltages as well as offer on/off control. This USB evaluation board features independent USB powering, virtual voltmeter bank all in a compact demonstration platform.

Key Features

- 2.7V to 5.5V input voltage range
- Programmable V_{OUT} 0.8V–3.3V
- Up to 95% efficiency
- ±3% output voltage accuracy
- 1.5A output current [bucks]

Applications

- Personal Media Players
- Smart Phones
- PDA Phones
- Digital Cameras

LP3971 Evaluation Board Version F

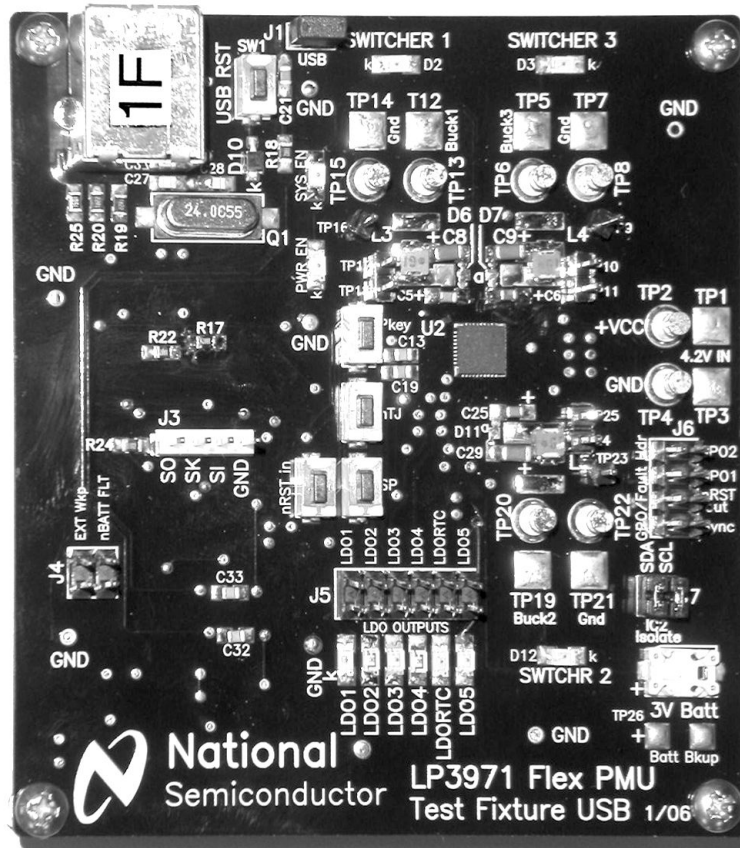

30018201

Evaluation Board/Kit Overview

The LP3971 Evaluation Board supports complete functional evaluation of the power management IC. The functions of the chip are controlled by the I²C interface. The I²C interface on the rev A, B, C, E, F and later USB boards are driven via a COP8 microprocessor which supports a connection via the USB port and offers chip powering and virtual software voltage measurement of all regulators. In addition, the LP3971 can be powered directly through the USB port for full function. If high current Buck testing is desired, an external LI ION cell or PS capable of supplying 2 amps will need to be connected to the appropriate connector.

The evaluation board/kit consists of:

- LP3971 Flex_PMU device soldered down in LQA-40 pin 5X5 LD package

- Full USB interface
- LED LDO monitoring with current limit resistors [selectable]
- External power LDO, Buck output and main battery/supply connectors offered in heavy duty turret pins and solder pads
- Socket for back-up battery
- Users guide
- CodeLoader Software version 1.2.0 or greater [may be sent via email]

LP3971 Flex_PMU USB Evaluation Board Block Operational Diagram

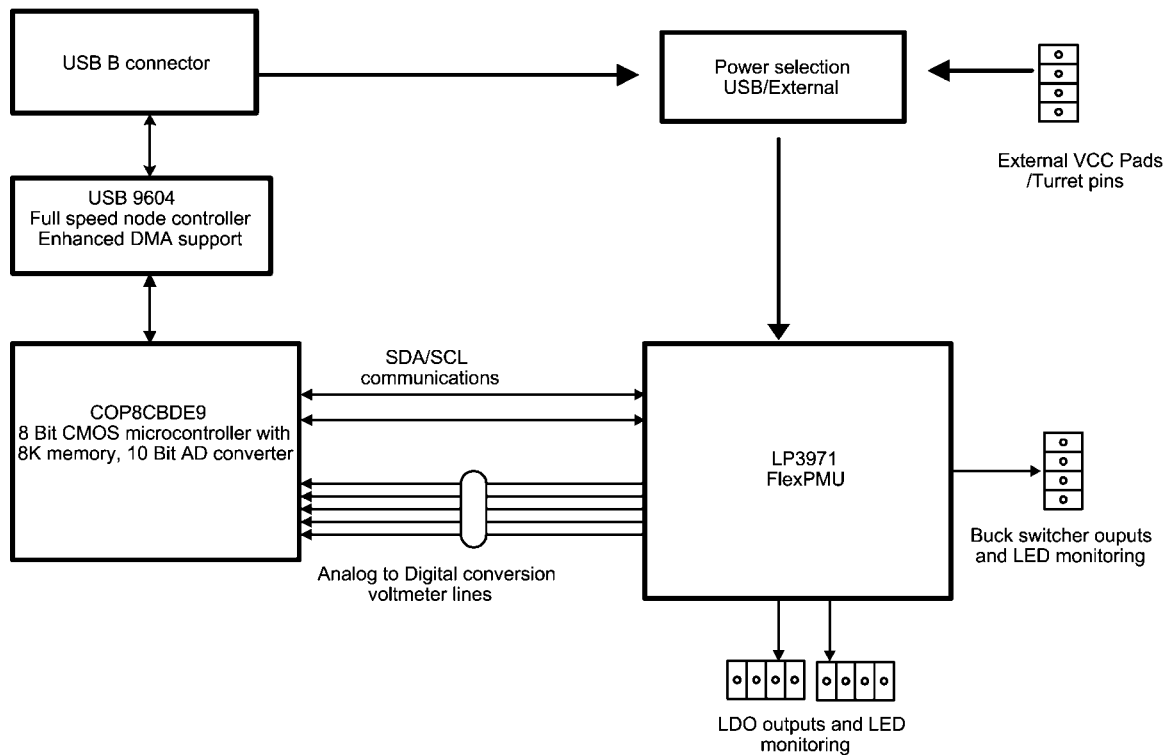

30018202

Pin Description 5X5 Package

Pin #	Name	I/O	Type	Description
1	PKEY	I	D	CPU Wakeup Input
2	nTJ	I	D	CPU Wakeup Input
3	SP	I	D	CPU Wakeup Input
4	EXT_WAKEUP	O	D	CPU Wakeup Input
5	FB1, Feedback Buck1	I	A	Buck 1 Feedback
6	$V_{IN1} = V_{Batt}$	I	P	Battery Input for Powering Internal Circuits and LDO1-3
7	LDO_V _{OUT_1}	O	P	LDO1 Output
8	LDO_V _{OUT_2}	O	P	LDO2 Output
9	nRST In	I	D	Chip Reset Input
10	LDO GND 1	G	G	Ground

Pin #	Name	I/O	Type	Description
11	LDO _{REF} Bypass	O	A	Bypass Capacitor for Reference
12	LDO_V _{OUT-3}	O	P	LDO3 Output
13	LDO_V _{OUT-4}	O	P	LDO4 Output
14	V _{IN} LDO_4	I	P	Input Power for LDO4
15	Back-Up Battery V _{IN}	I	P	Back Up Battery Input
16	LDO_V _{OUT-0} (RTC)	O	P	LDO-RTC Output
17	nBatt_FLT	O	D	Main Battery Fault Output
18	PGND Buck2	G	G	Ground
19	V _{OUT} Buck2	O	P	Buck Switcher 2 Output
20	V _{IN} Buck2	I	P	Buck Switcher 2 Battery Input
21	SDA	I/O	D	I ² C Data Line
22	SCL	I	D	I ² C Clock Input
23	FB2, Feedback Buck2	I	A	Buck Switcher 2 Feedback
24	nRST Out	O	D	Reset Output
25	LDO_V _{OUT-5}	O	P	LDO5 Output
26	V _{IN2} (LDO 5 Only)	I	P	Battery Input Power for LDO5
27	VDDA	I	P	Analog Power Input
28	FB3, Feedback Buck3	I	A	Buck Switcher 3 Feedback
29	GPIO1	I/O	D	General Purpose I/O #1
30	GPIO2	I/O	D	General Purpose I/O #2
31	V _{IN} Buck3	I	P	Buck Switcher 3 Battery Input
32	V _{OUT} Buck3	I	P	Buck Switcher 2 Output
33	PGND Buck3	G	G	Buck3 NMOS Power Ground
34	Buck 1 2 & 3 AVSS/NCHBLK	G	G	Buck1, 2, 3 Analog Ground
35	SYNC (Buck Clock Input)	I	D	Buck Switcher External Clock Input
36	Sys_En	I	D	Power Domain Enable
37	Pwr_En	I	D	Power Domain Enable
38	PGND Buck1	G	G	Buck1 NMOS Power Ground
39	V _{OUT} Buck1	O	P	Buck Switcher 1 Output
40	V _{IN} Buck1	I	P	Buck Switcher 1 Battery Input

A: Analog Pin

D: Digital Pin

G: Ground Pin

P: Power Pin

I: Input Pin

I/O: Input/Output

O: Output Pin

Operating Instructions

The following instructions give general instructions for use of LP3971 with the evaluation board. Practice standard ESD protection (ground cable) to prevent any unwanted damaging ESD events.

- Check that the jumpers are in default settings (jumpers are introduced later on this document).
- Load version 1.2.0 or later of the codeloader program into PC.
- Connect the USB cable [standard USB AB cable] from the USB connector to PC port.
- Open the codeloader program up, verify that "USB" port has been selected.
- Verify that successful communications link has been established by toggling "READ ALL".
- If there is no communication, key the USB RST [SW1] switch once on the board for reboot.
- If the voltmeter monitoring function is desired, select "POLL STATUS".
- LDO/buck outputs may be monitored directly off the appropriate header output pins.
- Note that for full load testing, an external PS must be connected to TP1/TP2 and jumper J1 must be removed. This is because the USB port source spec is limited to 500 mA and removing the jumper will disconnect the USB supply.
- PWR EN/SYS En is selectable via codeloader software assignment.
- Hardware reset can be accomplished by pressing the nREST_In momentary switch.
- Battery backup is possible by inserting appropriate rechargeable cell into supplied holder.
- Switches PKEY, nTJ, and SP, are provided for use in normal evaluation mode.

List of Components

March 03, 2006

Item	Qty.	Reference	Value	Pkg.	Manuf.	Part Number
1	5	C1, C21, CC, CD, CF1	10 μ F	0805	Panasonic	ECJ2FF1A106Z
2	2	C2, C3	100 μ F	3528-21	Kemet	T520B107M006ASE040
3	8	C4, C7, C13, C15, C16, C31, CA, CB	1 μ F	0805	Kemet	C0805C105K4RACTU
4	6	C5, C6, C8, C9, C25, C29	10 μ F	1206	Taiyo-Yuden	JMK316BJ106M
5	6	C14, C19, C20, C23, C24, C26	0.47 μ F	0805	TDK	C2012X7R1E474K
6	2	C17, C18	47 μ F	0805	Murata	GRM2195C2A470JZ01D
7	4	C22, C30, C32, C33	0.1 μ F	0805	Murata	GRM21BR71E104KA01L
8	2	C27, C28	15 pF	0805	Yageo	0805CG150J9B200
9	1	BT2	Battery Holder	SMT	Seiko	BH0414
10	1	NOT INSTALLED	Backup Battery	Micro4	Seiko	MS412F
11	4	D6, D7, D10, D11	Schottky	PM 457	On Semi	MBRM120LT3
12	2	D8 (PWR EN), D9 (SYS EN)	Green LED	1206	Lumex	SML-LX1206GC-TR
13	9	LDO1(D13), LDO2(D14), LDO3(D18), LDO4(D17), LD05(D19), LDORTC(D16), D2, D3, D12	Red LED	1206	Lumex	SML-LX1206IC-TR
14	2	L1, L2	1 μ H Inductor	0805	TDK	MLF2012A1R0K
15	3	L3, L4, L5	2.2 μ H Inductor	SMT	Toko	FDSE0312
16	1	Q1	XTAL 24 MHz 18 pF	SMD	Citizen	HCM49-24.000MABJT
17	7	R1, R2, R23, R31, R32, R33, R34	330 Ω	0805	SEI	807065R330
18	1	R8	100 Ω	0805	NIC	NRC10J101TR
19	1	R9	49.9 Ω	0805	Rohm	MCR10EZHF49R9
20	10	R10, R11, R12, R18, R22, R24, R26, R27, R36, R37	10K	0805	Yaego	9C08052A1002FKHFT
21	1	R12	0 Ω	0805	Yageo	9C08052A0R00JLHFT
22	4	R15, R16, R28, R29	133 Ω	0805	Rohm	MCR10EZHF1330
23	2	R19, R20	22.1 Ω	0805	Vishay-Dale	CRCW080522R1ERT1
24	1	R21	1M	0805	Yageo	9C08052A1004JLH
25	1	R25	1.5k	0805	Yageo	9C08052A1501FKH
26	1	D1	45.3 Ω	0805	Vishay-Dale	CRCW080545R3F100
27	5	S1, S2, S3, S4, SW1	Touch Switch	SMD	Panasonic	EVQ-PJU04K
28	1	U1	3.3V Regulator	SOT-23 5	NSC	LP2981AIM5-3.3
29	1	U2	PMU	SQF-40	NSC	LP3971SQ
30	1	U3	USB Controller	SOIC 28	NSC	USBN9604-28M
31	1	U4	Microcontroller	TSSOP 48	NSC	COP8CBE9IMT9
32	1	U5	2V Regulator	SOT-23 5L	NSC	LP3984IMF-2.0
33	1	U6	Voltage Converter	SOT-23-6	NSC	LM2664M6
34	1	J1	100 mil Header	2 pos	Amp	1 X 2 (4-103239-0-02)
35	1	J2	USB Receptacle	4 pos	FCI	61729-0010B
36	1	J3	100 mil Header	4 pos	Molex	1 X 4 (22-10-2041)
37	1	J4	100 mil Header	4 pos	Amp	2 X 2 (4-103240-0-02)
38	1	J5	100 mil Header	12 pos	Amp	2 X 5 (4-103240-0-06)
39	1	J6	GPO/LDO Headers	8 pos	Amp	2 X 4 (4-103186-0-04)
40	1	J7	2 mm Header	4 pos	Sullins	2 X 2 (PRPN022MAMP)

Item	Qty.	Reference	Value	Pkg.	Manuf.	Part Number
41	10	TP9, TP10, TP11, TP16, TP17, TP18, TP23, TP24, TP25, TP26	Test Points	1 pos	Amp	1 X (4-103185-0-01)
42	8	TP2, TP4, TP6, TP8, TP13, TP15, TP20, TP22	Turrett Terminal	0.109"L	Keystone	1502-2
43	1	LP3971 version F Fab	Bare Board	4 Layer	Rainbow Labs	LP3971-F

Powering and Jumpers Selection

The LP3971 USB evaluation platform offers several power connectors. These connectors are outlined in the table below. In addition, the Evaluation board has jumpers for special

modes and stand-alone use. The default jumper settings are valid in normal operation and are also outlined below.

Component	Use	Comment
J5-1	Output for LDO1	Outside Pin of Connector is Grd
J5-2	Output for LDO2	Outside Pin of Connector is Grd
J5-3	Output for LDO3	Outside Pin of Connector is Grd
J5-4	Output for LDO4	Outside Pin of Connector is Grd
J5-6	Output for LDO5	Outside Pin of Connector is Grd
J5-5	Output for RTC [Real Time Clock]	Outside Pin of Connector is Grd
J4-1	Input for External Wakeup	Outside Pin of Connector is Grd
J4-2	Output for nBATT Fault	Outside Pin of Connector is Grd
J6-2	Output for nREST	Outside Pin of Connector is Grd
J6-3	GPO 1 Output	Outside Pin of Connector is Grd
J6-4	GPO 2 Output	Outside Pin of Connector is Grd
J3-1	Cop8 Microwire SO	Used for Micro Flash Only
J3-2	Cop8 Microwire SK	Used for Micro Flash Only
J3-3	Cop8 Microwire SI	Used for Micro Flash Only
J3-4	Cop8 Grd	Used for Micro Flash Only
TP12-13	Output for Swicher Buck 1	GRD is TP12-13
TP19-20	Output for Swicher Buck 2	GRD is TP21-22
TP5-6	Output for Swicher Buck 3	GRD is 7-8
USB	USB Connector	Connect to the PC Via Supplied Cable
J1	Power Usage Seletion	Place Jumper for USB, NO JUMPER for External Power Input
TP1-2	Connect External V _{CC} Supply Here 3.5V–5V for High Current Testing	Doubles for LI-ION cell Input

Demonstration Software Window

The demonstration software enables read and write to LP3971's internal registers through PC's USB port. All the user controllable registers are usable through the software.

Installation: Run the codeloader for LP3971 version 1.2.0 or greater.

After startup the user can verify that successful USB communication has been established by selecting "Read All", the default programmed voltages should appear.

LDO's can be enabled and disabled by clicking mouse left button on the square close to each LDO voltage slider. Changing the virtual slider changes the LDO voltage. After the WRITE button is pressed subsequent LDO changes are applied if the 'autowrite' feature is disabled.

Note 'Autowrite' enabled is default. In the case of the buck control, an option for 'hold' or 'go' can be selected. Note voltage will not change until the 'go' selection is made.

The virtual voltmeters can be activated by selecting 'Poll Status', after which an A to D conversion is read and displayed for each subsequent LDO and Buck output. Note that this feature is meant to be a general measurement and "may" be subject to variations due to operations noise.

Since there is a bi-directional SDA feature, any register and its contents can be determined by entering the desired register address and selecting 'Read'. In addition, any corresponding register may be written directly to via the 'Store' selection. All virtual sliders can be updated via the 'Read All' Tab. Direct register control is possible by entering the desired address and value followed by a 'Store' command.

LP3971 Control Panel (ver 1.2.2)

File Settings Help

Direct Register Access
 Addr (HEX): 0 Store Addr (HEX): 0 Read
 Data: 7 6 5 4 3 2 1 0 Data (BIN):

Registers Profile
 0: Save Load Def
 1: Save Load Def
 Interface Port: USB

Main Control

LDO / BUCK Output Enable Control

LDO1	LDO2	LDO3	LDO4	LDO5	BUCK1	BUCK2	BUCK3
On	On	On	On	On	On	On	On
Ok	Ok	Ok	Ok	Ok	Ok	Ok	Ok

2.99V 2.98V 2.98V 1.29V 1.09V 1.41V 3.00V 1.81V

LDO Output Voltage Selection

LDO1	LDO2	LDO3	LDO4	LDO5
3.0V	3.0V	3.0V	1.30V	1.10V

BUCK Output Voltage Selection

BUCK1	RAMP	BUCK2	RAMP	BUCK3	RAMP
1.40V	1.40V	3.00V	3.00V	1.80V	1.80V
V1	V2	V1	V2	V1	V2

Charger Control
 Charger Current: 500 uA
 Threshold Voltage: 2.8/3.0V
 Enable Charger
 Enable Threshold
 Disable Backup Battery
 Enable precharge
 GPIO1 pin as Enable Charger
 Shut Charger to VDDA

Control / Status bits and I/O pins

<input type="checkbox"/> Enable LDO5 from SYSEN to PWREN	<input type="checkbox"/> Bypass SYS_EN pin	GPIO1: HZ IN LO HI 0
<input checked="" type="checkbox"/> Enable Buck2 by SYS_EN	<input type="checkbox"/> Enable ext clock for bucks	GPIO2: HZ IN LO HI 0
<input type="checkbox"/> Enable LDO4 by SYS_EN	<input type="checkbox"/> Enable Spread Spectrum (SS)	Pin nCHG_EN: 1 Pin nTEST_JIG: 1
<input checked="" type="checkbox"/> Enable neg-polarity for SPARE input	<input checked="" type="checkbox"/> Set SS modulation: 2 or 10 kHz	Pin SPARE: 1 Pin PWR_ON: 0
<input type="checkbox"/> Bypass LDO_RTC voltage tracking		Wakeup reason: Pin nTEST_JIG
<input type="checkbox"/> Soft PWR_EN Temp: Ok SYS_EN delay: Bypass		

Set SYS_EN pin Set EXT_WAKEUP pin
 Set PWR_EN pin Set nBATT_FLT pin

Measure Defaults ReadAll WriteAll Auto Write Poll status (1s)

PC I/F: USB CHIP I/F: PC @ 34h OK VDD=1.84V LDO_RTC=3.02V 11:95

30018203

Layout Details

Top Silkscreen

TOP SILKSCREEN LEGEND

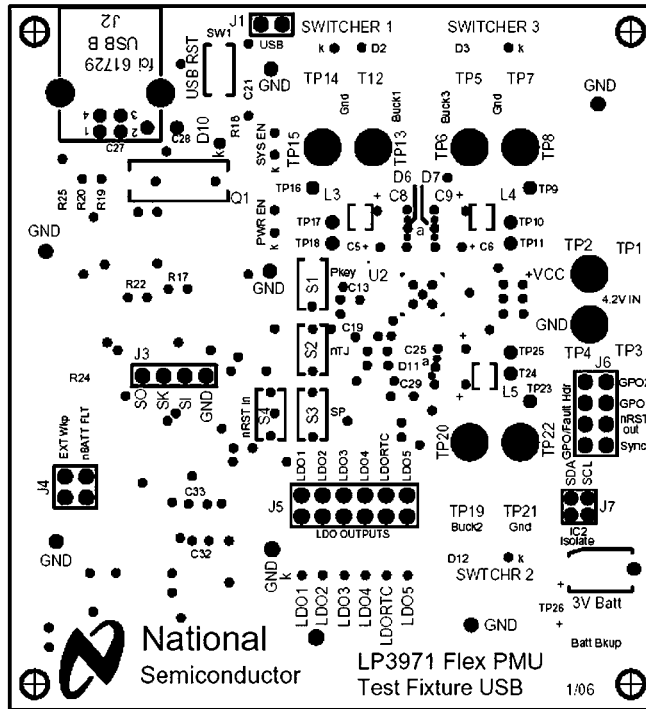

30018205

Top Trace

TOP (Component Side) Layer 1

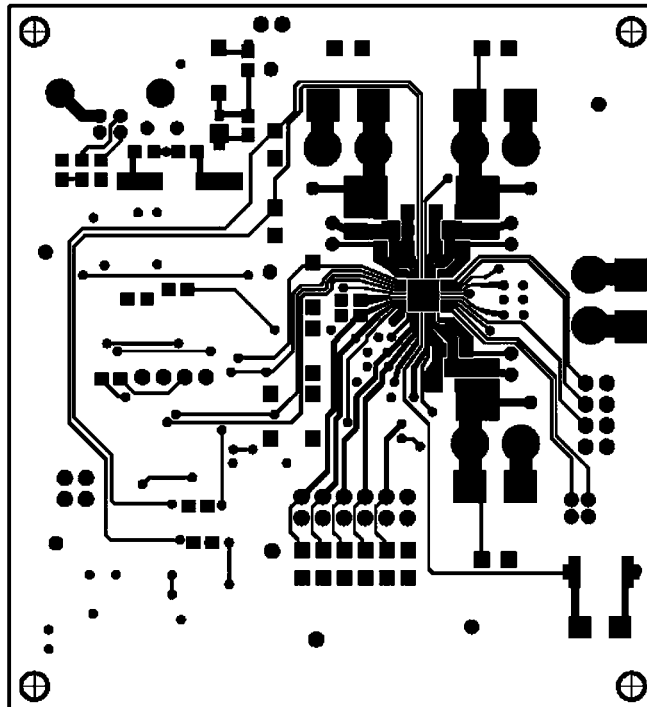

30018206

Bottom Trace

Bottom (Solder Side) Layer 4

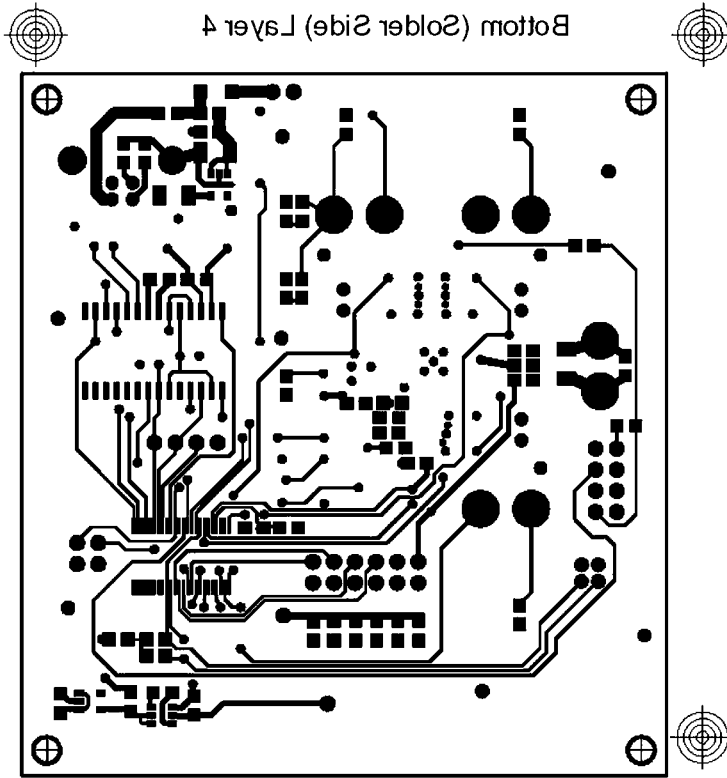

30018207

Bottom Silkscreen

BOTTOM SILKSCREEN LEGEND

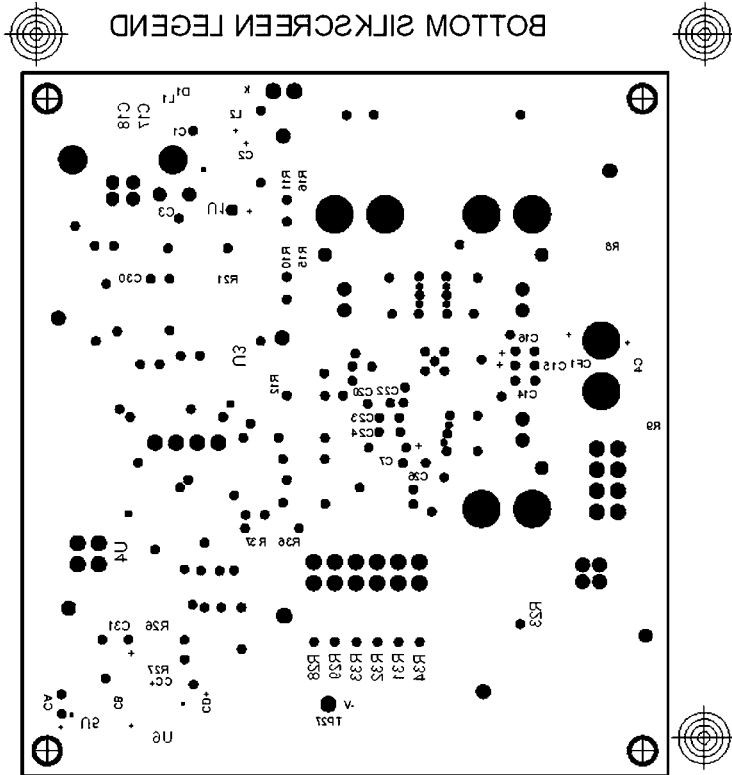

30018208

Bare Board/Component Locations

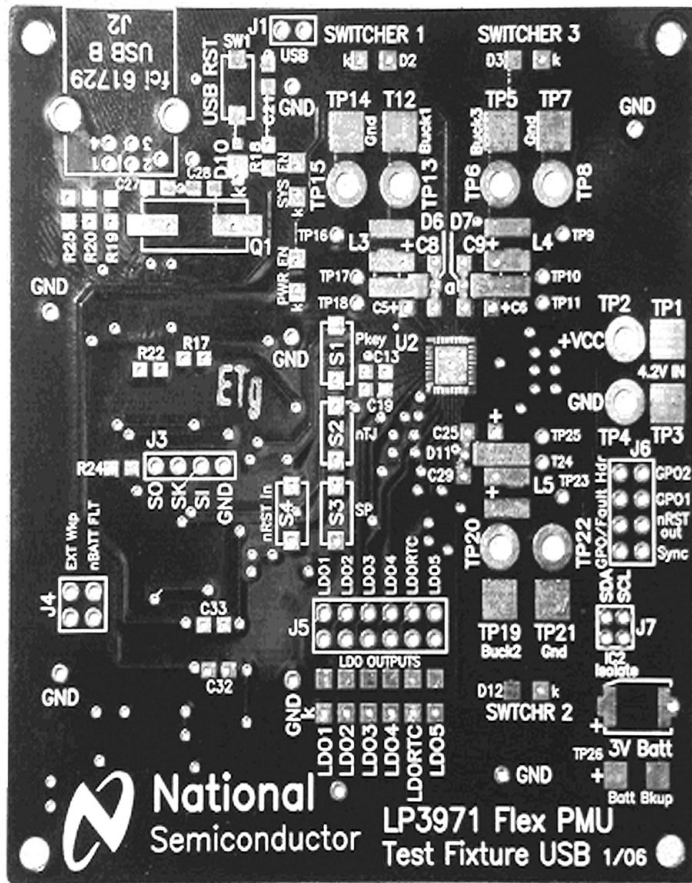

30018209

Notes

THE CONTENTS OF THIS DOCUMENT ARE PROVIDED IN CONNECTION WITH NATIONAL SEMICONDUCTOR CORPORATION ("NATIONAL") PRODUCTS. NATIONAL MAKES NO REPRESENTATIONS OR WARRANTIES WITH RESPECT TO THE ACCURACY OR COMPLETENESS OF THE CONTENTS OF THIS PUBLICATION AND RESERVES THE RIGHT TO MAKE CHANGES TO SPECIFICATIONS AND PRODUCT DESCRIPTIONS AT ANY TIME WITHOUT NOTICE. NO LICENSE, WHETHER EXPRESS, IMPLIED, ARISING BY ESTOPPEL OR OTHERWISE, TO ANY INTELLECTUAL PROPERTY RIGHTS IS GRANTED BY THIS DOCUMENT.

TESTING AND OTHER QUALITY CONTROLS ARE USED TO THE EXTENT NATIONAL DEEMS NECESSARY TO SUPPORT NATIONAL'S PRODUCT WARRANTY. EXCEPT WHERE MANDATED BY GOVERNMENT REQUIREMENTS, TESTING OF ALL PARAMETERS OF EACH PRODUCT IS NOT NECESSARILY PERFORMED. NATIONAL ASSUMES NO LIABILITY FOR APPLICATIONS ASSISTANCE OR BUYER PRODUCT DESIGN. BUYERS ARE RESPONSIBLE FOR THEIR PRODUCTS AND APPLICATIONS USING NATIONAL COMPONENTS. PRIOR TO USING OR DISTRIBUTING ANY PRODUCTS THAT INCLUDE NATIONAL COMPONENTS, BUYERS SHOULD PROVIDE ADEQUATE DESIGN, TESTING AND OPERATING SAFEGUARDS.

EXCEPT AS PROVIDED IN NATIONAL'S TERMS AND CONDITIONS OF SALE FOR SUCH PRODUCTS, NATIONAL ASSUMES NO LIABILITY WHATSOEVER, AND NATIONAL DISCLAIMS ANY EXPRESS OR IMPLIED WARRANTY RELATING TO THE SALE AND/OR USE OF NATIONAL PRODUCTS INCLUDING LIABILITY OR WARRANTIES RELATING TO FITNESS FOR A PARTICULAR PURPOSE, MERCHANTABILITY, OR INFRINGEMENT OF ANY PATENT, COPYRIGHT OR OTHER INTELLECTUAL PROPERTY RIGHT.

LIFE SUPPORT POLICY

NATIONAL'S PRODUCTS ARE NOT AUTHORIZED FOR USE AS CRITICAL COMPONENTS IN LIFE SUPPORT DEVICES OR SYSTEMS WITHOUT THE EXPRESS PRIOR WRITTEN APPROVAL OF THE CHIEF EXECUTIVE OFFICER AND GENERAL COUNSEL OF NATIONAL SEMICONDUCTOR CORPORATION. As used herein:

Life support devices or systems are devices which (a) are intended for surgical implant into the body, or (b) support or sustain life and whose failure to perform when properly used in accordance with instructions for use provided in the labeling can be reasonably expected to result in a significant injury to the user. A critical component is any component in a life support device or system whose failure to perform can be reasonably expected to cause the failure of the life support device or system or to affect its safety or effectiveness.

National Semiconductor and the National Semiconductor logo are registered trademarks of National Semiconductor Corporation. All other brand or product names may be trademarks or registered trademarks of their respective holders.

Copyright© 2007 National Semiconductor Corporation

For the most current product information visit us at www.national.com



National Semiconductor Americas Customer Support Center
 Email: new.feedback@nsc.com
 Tel: 1-800-272-9959

National Semiconductor Europe Customer Support Center
 Fax: +49 (0) 180-530-85-86
 Email: europe.support@nsc.com
 Deutsch Tel: +49 (0) 69 9508 6208
 English Tel: +49 (0) 870 24 0 2171
 Français Tel: +33 (0) 1 41 91 8790

National Semiconductor Asia Pacific Customer Support Center
 Email: ap.support@nsc.com

National Semiconductor Japan Customer Support Center
 Fax: 81-3-5639-7507
 Email: jpn.feedback@nsc.com
 Tel: 81-3-5639-7560